

Instruction Manual

R 5

Oil-Lubricated Rotary Vane Vacuum Pumps

RA 0160 D, RA 0202 D, RA 0250 D, RA 0302 D



CE EAC

Ateliers Busch S.A.
Zone industrielle, 2906 Chevenez
Switzerland

Table of Contents

1	Safety	3
2	Product Description	4
2.1	Operating Principle	5
2.2	Application	5
2.3	Optional Accessories	5
2.3.1	Gas Ballast Valve	5
2.3.2	Inlet Filter	5
2.3.3	Water-oil Heat Exchanger	5
2.3.4	Temperature Switch	5
2.3.5	Resistance Thermometer	6
2.3.6	Level and Temperature Switch	6
2.3.7	Pressure Switch	6
2.3.8	Pressure Transmitter	6
3	Transport	6
4	Storage	7
5	Installation	8
5.1	Installation Conditions	8
5.2	Connecting Lines / Pipes	8
5.2.1	Suction Connection	9
5.2.2	Discharge Connection	9
5.2.3	Cooling Water Connection (Optional)	10
5.3	Filling Oil	11
5.4	Electrical Connection	11
5.4.1	Wiring Diagram Three-Phase Motor	12
5.5	Electrical Connection of the Monitoring Devices	13
5.5.1	Wiring Diagram Temperature Switch (Optional)	13
5.5.2	Wiring Diagram Resistance Thermometer (Optional)	13
5.5.3	Wiring Diagram Level and Temperature Switch (Optional)	13
5.5.4	Wiring Diagram Pressure Switch (Optional)	13
5.5.5	Wiring Diagram Pressure Transmitter (Optional)	14
6	Commissioning	14
6.1	Conveying Condensable Vapours	14
7	Maintenance	15
7.1	Maintenance Schedule	16
7.2	Oil Level Inspection	16
7.3	Oil and Oil Filter Change	17
7.4	Exhaust Filter Change	18
8	Overhaul	19
9	Decommissioning	20
9.1	Dismantling and Disposal	20
10	Spare Parts	20
11	Troubleshooting	21
12	Technical Data	23
13	Oil	23
14	EU Declaration of Conformity	24

1 Safety

Prior to handling the machine, this instruction manual should be read and understood. If anything needs to be clarified, please contact your Busch representative.

Read this manual carefully before use and keep for future reference.

This instruction manual remains valid as long as the customer does not change anything on the product.

The machine is intended for industrial use. It must be handled only by technically trained personnel.

The machine has been designed and manufactured according to state-of-the-art methods. Nevertheless, residual risks may remain. This instruction manual highlights potential hazards where appropriate. Safety notes and warning messages are tagged with one of the keywords DANGER, WARNING, CAUTION, NOTICE and NOTE as follows:

DANGER

... indicates an imminent dangerous situation that will result in death or serious injuries if not prevented.

WARNING

... indicates a potentially dangerous situation that could result in death or serious injuries.

CAUTION

... indicates a potentially dangerous situation that could result in minor injuries.

NOTICE

... indicates a potentially dangerous situation that could result in damage to property.

NOTE

... indicates helpful tips and recommendations, as well as information for efficient and trouble-free operation.

2 Product Description

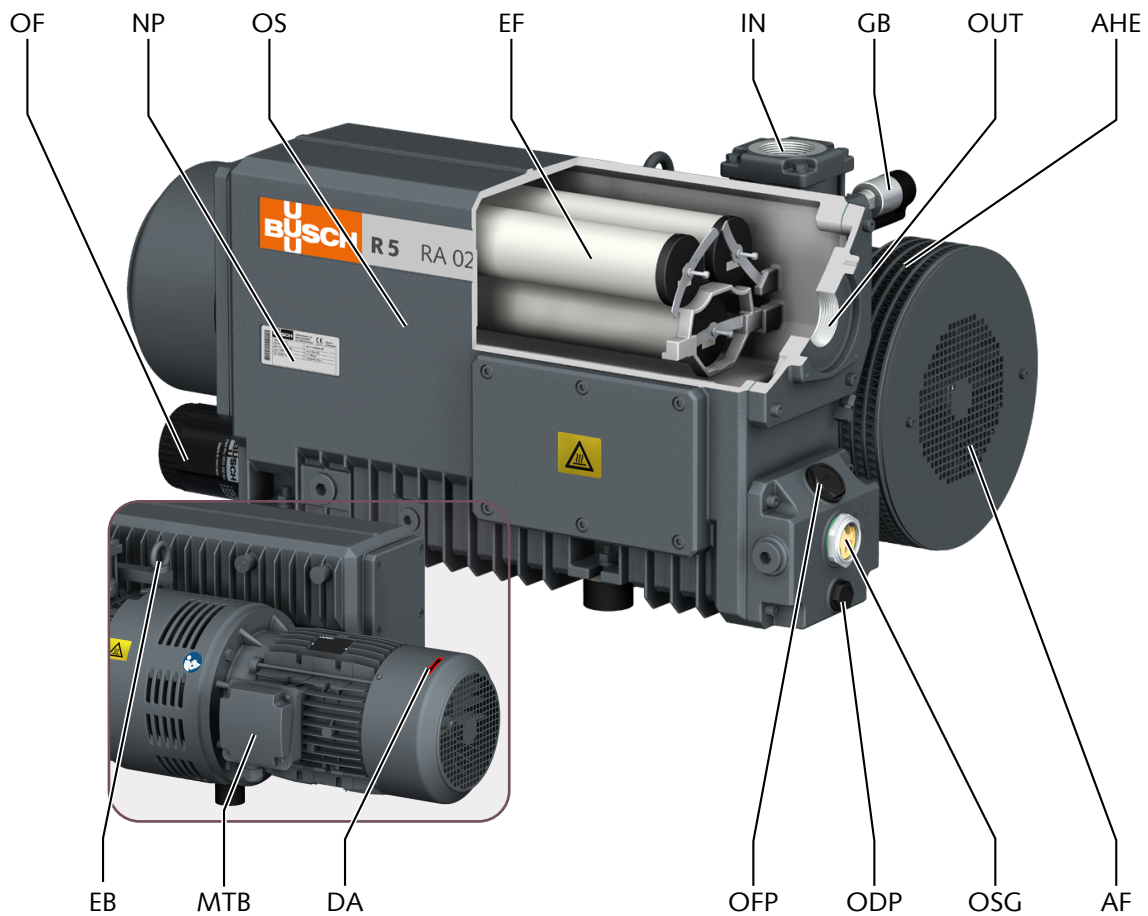

IN	Suction connection	MTB	Motor terminal box
OUT	Discharge connection	DA	Directional arrow
OFF	Oil fill plug	EF	Exhaust filter
OSG	Oil sight glass	NP	Nameplate
ODP	Oil drain plug	OF	Oil filter
EB	Eye bolt	AF	Axial fan
GB	Gas ballast valve	OS	Oil separator
AHE	Air-oil heat exchanger		

i NOTE

Technical term.

In this instruction manual, we consider that the term 'machine' refers to the 'vacuum pump'.

2.1 Operating Principle

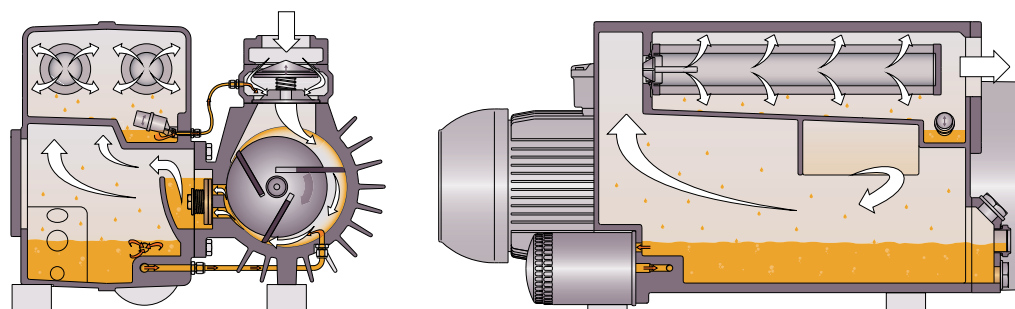

The machine works on the rotary vane principle.

The oil seals the gaps, lubricates the vanes and takes away compression heat.

The oil filter cleans the circulating oil.

Exhaust filters separate the oil from the discharged gas.

2.2 Application

The machine is intended for the suction of air and other dry, non-aggressive, non-toxic and non-explosive gases.

Conveying of other media leads to an increased thermal and/or mechanical load on the machine and is permissible only after a consultation with Busch.

The machine is intended for the placement in a non-potentially explosive environment.

The machine is capable of maintaining ultimate pressure.

The machine is suitable for continuous operation.

Permitted environmental conditions see Technical Data [▶ 23].

2.3 Optional Accessories

2.3.1 Gas Ballast Valve

The gas ballast valve mixes the process gas with a limited quantity of ambient air to counteract the condensation of vapour inside the machine.

2.3.2 Inlet Filter

The inlet filter protects the machine against dust and other solids in the process gas. The inlet filter is available with a paper or polyester cartridge.

2.3.3 Water-oil Heat Exchanger

In case of unfavourable ambient conditions a water-oil heat exchanger can be provided.

2.3.4 Temperature Switch

The temperature switch monitors the oil temperature of the machine.

Depending on the oil type, the machine must be stopped when the oil reaches a certain temperature, see Oil [▶ 23].

2.3.5 Resistance Thermometer

The resistance thermometer monitors the oil temperature of the machine.

Depending on the oil type, a warning and a trip signals must be set, see Oil [▶ 23].

2.3.6 Level and Temperature Switch

The level switch with integrated temperature switch monitors the oil level and the oil temperature. It has one level switch point and two temperature switch points.

The machine must be stopped when the oil level is too low or, depending on the oil type, when the oil reaches a certain temperature, see Oil [▶ 23].

2.3.7 Pressure Switch

The pressure switch monitors the pressure in the oil separator.

The machine must be stopped when the gas reaches a certain pressure, see Wiring Diagram Pressure Switch (Optional) [▶ 13].

2.3.8 Pressure Transmitter

The pressure transmitter monitors the pressure in the oil separator.

A warning and a trip signals must be set, see Wiring Diagram Pressure Transmitter (Optional) [▶ 14].

3 Transport



WARNING

Suspended load.

Risk of severe injury!

- Do not walk, stand or work under suspended loads.



NOTICE

In case the machine is already filled with oil.

Tilting a machine that is already filled with oil can cause large quantities of oil to ingress into the cylinder. Starting the machine with excessive quantities of oil in the cylinder will immediately break the vanes and ruin the machine!

- Drain the oil prior to every transport or always horizontally transport the machine.

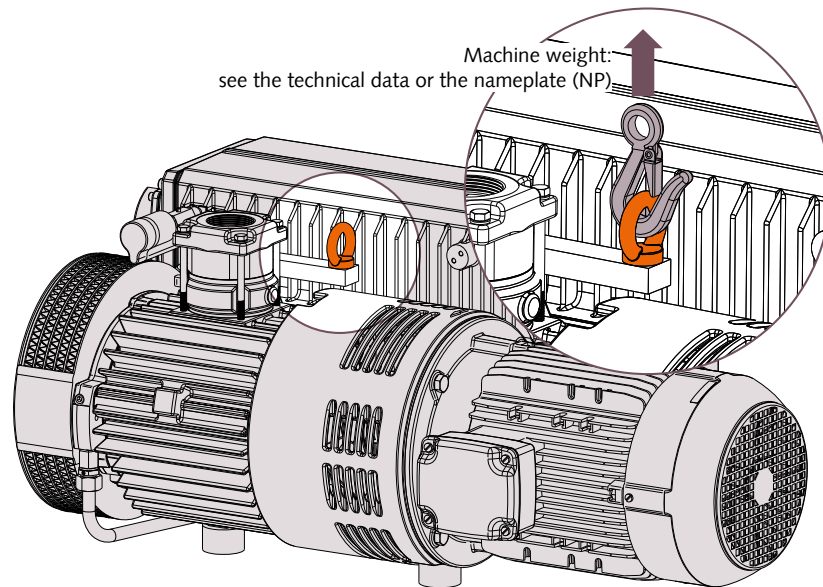

- Check the machine for transport damage.

If the machine is secured to a base plate:

- Remove the machine from the base plate.



WARNING

Lifting the machine using the motor eye bolt.

Risk of severe injury!

- Do not lift the machine using the eye bolt fitted to the motor. Only lift the machine as previously shown.

4 Storage

- Seal all apertures with adhesive tape or reuse provided caps.

Version with water-oil heat exchanger:

- Make sure that the cooling water has been completely removed, see Decommissioning [► 20].

If the machine is to be stored for more than 3 months:

- Wrap the machine in a corrosion inhibiting film.
- Store the machine indoors, dry, dust free and if possible in original packaging preferably at temperatures between 0 ... 40 °C.

5 Installation

5.1 Installation Conditions

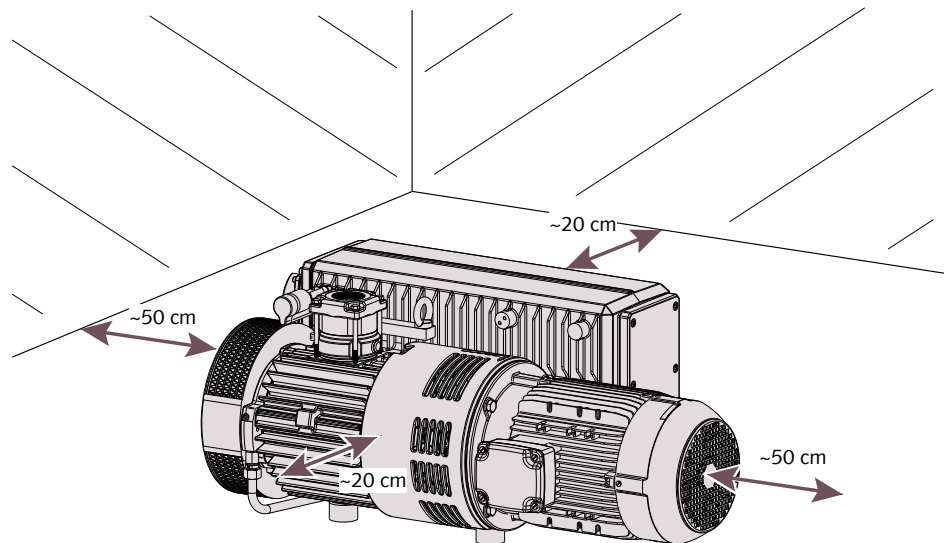

- Make sure that the environment of the machine is not potentially explosive.
- Make sure that the ambient conditions comply with the Technical Data [▶ 23].
- Make sure that the environmental conditions comply with the protection class of the motor.
- Make sure that the installation space or location is vented such that sufficient cooling of the machine is provided.
- Make sure that cooling air inlets and outlets are not covered or obstructed and that the cooling air flow is not affected adversely in any other way.
- Make sure that the oil sight glass (OSG) remains easily visible.
- Make sure that enough space remains for maintenance work.
- Make sure that the machine is placed or mounted horizontally, a maximum of 1° in any direction.
- Check the oil level, see Oil Level Inspection [▶ 16].
- Make sure that all provided covers, guards, hoods, etc. are mounted.

Version with water-oil heat exchanger:

- Make sure that the cooling water complies with the requirements, see Cooling Water Connection (Optional) [▶ 10].

If the machine is installed at an altitude greater than 1000 meters above sea level:

- Contact your Busch representative, the motor should be derated or the ambient temperature limited.

5.2 Connecting Lines / Pipes

- Make sure that the connection lines cause no stress on the machine's connection; if necessary use flexible joints.
- Make sure that the line size of the connection lines over the entire length is at least as large as the connections of the machine.

In case of very long connection lines it is advisable to use larger line sizes in order to avoid a loss of efficiency. Seek advice from your Busch representative.

5.2.1 Suction Connection

WARNING

Unprotected suction connection.

Risk of severe injury!

- Do not put hand or fingers in the suction connection.

NOTICE

Intruding foreign objects or liquids.

Risk of damage to the machine!

If the inlet gas contains dust or other foreign solid particles:

- Install a suitable filter (5 micron or less) upstream from the machine.

Connection size:

- G2

Depending on the specific order, other connection dimensions may apply.

If the machine is used as part of a vacuum system:

- Busch recommends the installation of an isolation valve in order to prevent the oil from flowing back to the vacuum system.

5.2.2 Discharge Connection

CAUTION

The discharge gas contains small quantities of oil.

Risk to health!

If air is discharged into rooms where persons are present:

- Make sure that sufficient ventilation is provided.

Connection size:

- G2

Depending on the specific order, other connection dimensions may apply.

- Make sure that the discharged gas will flow without obstruction. Do not shut off or throttle the discharge line or use it as a pressurised air source.

Unless the aspirated air is discharged to the environment right at the machine:

- Make sure that the discharge line either slopes away from the machine or provide a liquid separator or a siphon with a drain cock, so that no liquids can flow back into the machine.

5.2.3 Cooling Water Connection (Optional)

Water-oil heat exchanger without inlet accessories

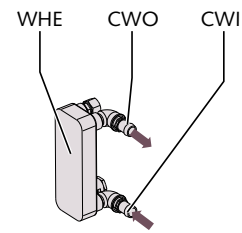
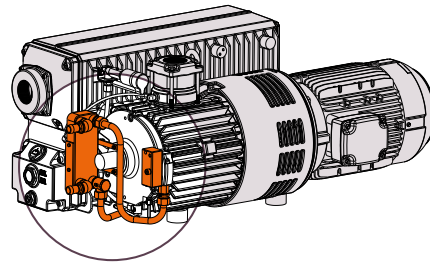

Water-oil heat exchanger with inlet accessories

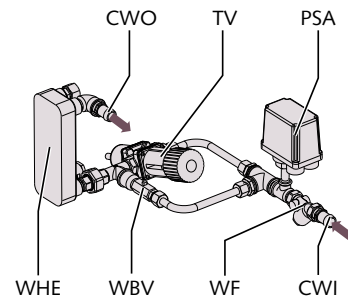
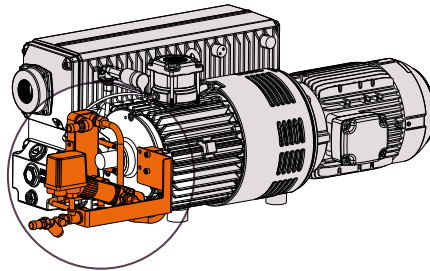

CWI	Cooling water inlet	PSA	Pressure switch
CWO	Cooling water outlet	WBV	Water bypass valve
WHE	Water-oil heat exchanger	WF	Water filter
TV	Thermostatic valve		

The factory default adjustment of the thermostatic valve (TV) is set in position 2 (approx. 75°C oil temperature).

Connection size:

- 19 mm hose (CWI / CWO)

- Make sure that the cooling water complies with the following requirements:

Min. supply capacity	l/min	2.5
Water pressure	bar	2 ... 6
Supply temperature	°C	+5 ... +35
Required pressure differential across supply and return	bar	≥ 1

- To reduce the maintenance effort and ensure a long product lifetime we recommend the following cooling water quality:

Hardness	mg/l (ppm)	< 90
Properties		Clean & clear
PH value		7 ... 8
Particle size	µm	< 200
Chloride	mg/l	< 100
Electrical conductivity	µS/cm	≤ 100
Free chloride	mg/l	< 0.3
Materials in contact with the cooling water		Stainless steel, copper and cast iron

i NOTE

Water hardness unit conversion.

1 mg/l (ppm) = 0.056 °dh (german degree) = 0.07 °e (english degree) = 0.1 °fH (french degree)

5.3 Filling Oil

For oil type and oil capacity see Technical Data [▶ 23] and Oil [▶ 23].

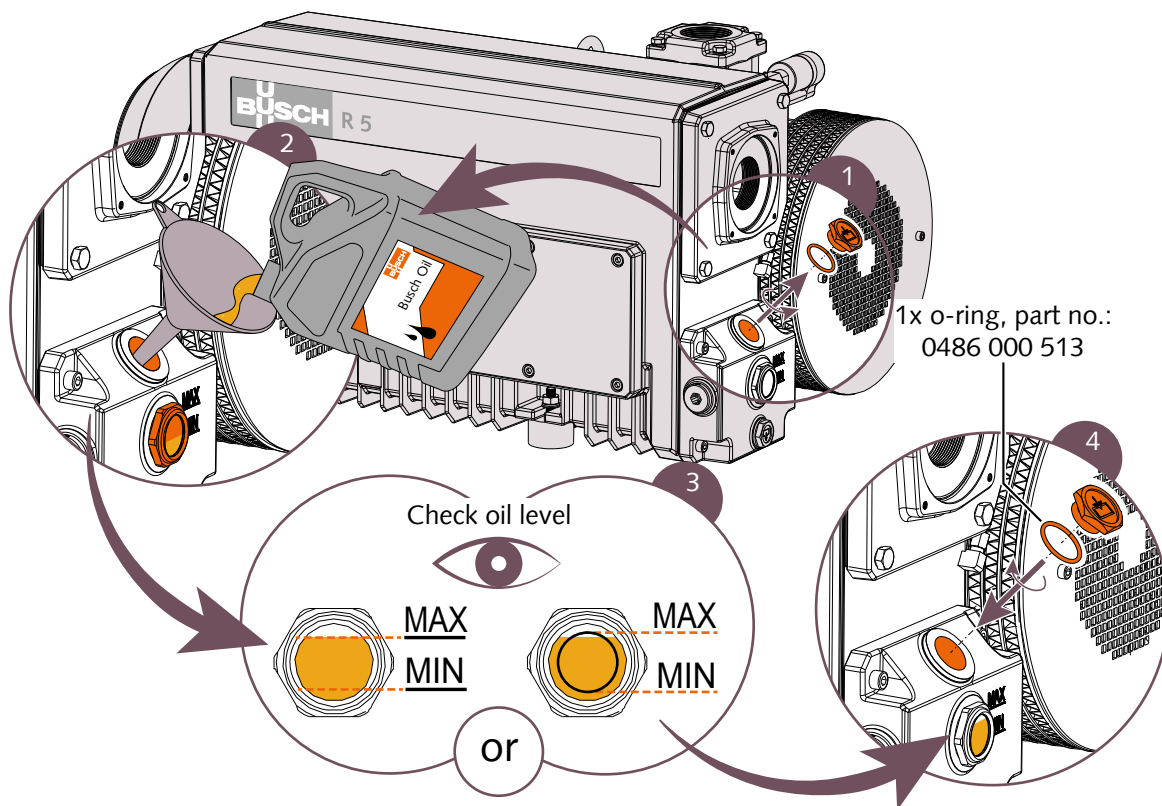

5.4 Electrical Connection

DANGER

Live wires.

Risk of electrical shock.

- Electrical installation work must only be executed by qualified personnel.
- Make sure that the power supply for the motor is compatible with the data on the nameplate of the motor.
- Provide overload protection according to EN 60204-1 for the motor.
- Connect the protective earth conductor.
- Electrically connect the motor.

NOTICE

Incorrect connection.

Risk of damage to the motor!

- The wiring diagrams given below are typical. Check the inside of the terminal box for motor connection instructions/diagrams.

5.4.1 Wiring Diagram Three-Phase Motor

Delta connection (low voltage):

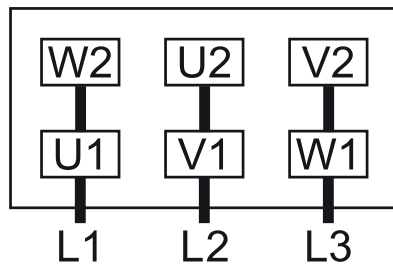

Star connection (high voltage):

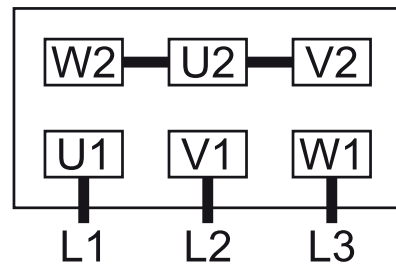

Double star connection, multi-voltage motor with 9 pins (low voltage):

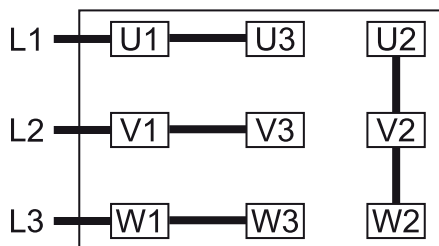

Star connection, multi-voltage motor with 9 pins (high voltage):

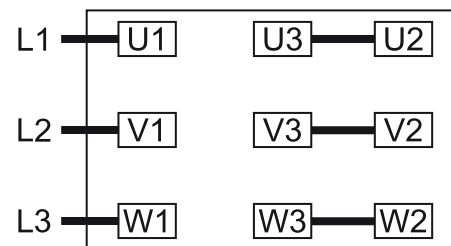

Double star connection, multi-voltage motor with 12 pins (low voltage):

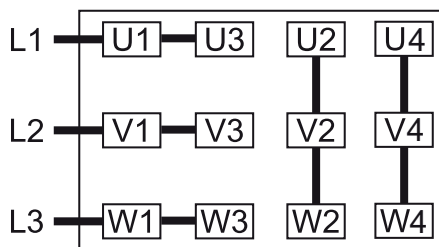

Star connection, multi-voltage motor with 12 pins (high voltage):

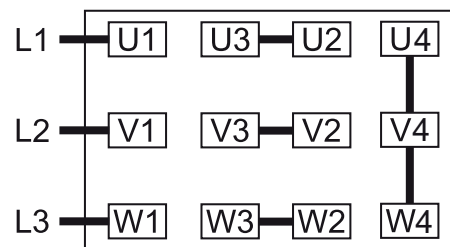

Delta connection, multi-voltage motor with 12 pins (middle voltage):

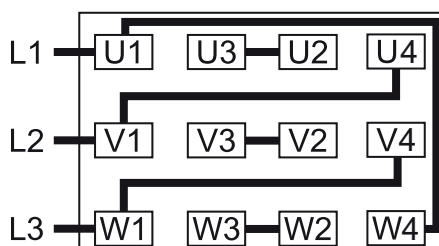

! NOTICE

Incorrect direction of rotation.

Risk of damage to the machine!

- Operation in the wrong direction of rotation can destroy the machine in a short time! Prior to start-up, ensure that the machine is operated in the right direction.
- Determine the intended direction of rotation with the arrow (stuck on or cast).
- Jog the motor briefly.

- Watch the fan wheel of the motor and determine the direction of rotation just before the fan wheel stops.

If the rotation must be changed:

- Switch any two of the motor phase wires.

5.5 Electrical Connection of the Monitoring Devices

NOTE

In order to prevent potential nuisance alarms, Busch recommends that the control system is configured with a time delay of at least 10 seconds.

5.5.1 Wiring Diagram Temperature Switch (Optional)

Part no.: 0651 563 747

Connector: M12x1, 4-pin

$U = \leq 250 \text{ V AC/DC (50/60 Hz)}$; $I = \leq 1 \text{ A}$

Switch point:

T_1 pin 1 + 2 = 110 °C*

T_2 pin 3 + 4 = 130 °C*

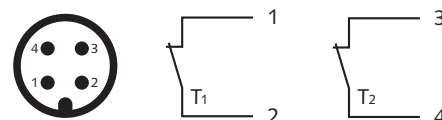

1 = Brown ; 2 = White ;
3 = Blue ; 4 = Black

* The switch point value depends on the oil type, see Oil [► 23].

5.5.2 Wiring Diagram Resistance Thermometer (Optional)

Part no.: 0651 563 753

Connector: M12x1, 4-pin

$U = 10 \dots 35 \text{ VDC}$

$4 \dots 20 \text{ mA} \blacktriangleright 0 \dots 150 \text{ °C}$

Warning / trip signals: see Oil [► 23].

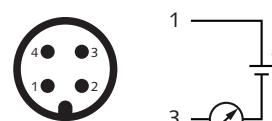

1 = Brown ; 3 = Blue

5.5.3 Wiring Diagram Level and Temperature Switch (Optional)

Part no.: 0652 563 748

Connector: M12x1, 4-pin

$U = \leq 230 \text{ V AC/DC (50/60 Hz)}$;

$I = \leq 0.5 \text{ A}$

Switch point:

L pin 1 + 4 = low level

T_1 pin 1 + 2 = 110 °C*

T_2 pin 1 + 3 = 130 °C*

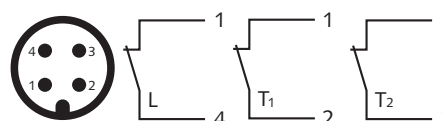

1 = Brown ; 2 = White ;
3 = Blue ; 4 = Black

* The switch point value depends on the oil type, see Oil [► 23].

5.5.4 Wiring Diagram Pressure Switch (Optional)

Part no.: 0653 563 750

Connector: M12x1, 4-pin

$U = \leq 250 \text{ V AC/DC (50/60 Hz)}$; $I = \leq 4 \text{ A}$

Switch point:

P pin 1 + 2 = 0.6 bar (overpressure)

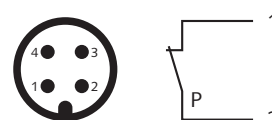

1 = Brown ; 2 = White

5.5.5 Wiring Diagram Pressure Transmitter (Optional)

Part no.: 0653 563 751

Connector: M12x1, 4-pin

U = 10 ... 35 VDC

4 ... 20 mA ► 0 ... 1 bar

Warning signal:

$P_{\text{warning}} = 0.4 \text{ bar}$ (overpressure)

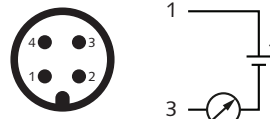

1 = Brown ; 3 = Blue

Trip signal:

$P_{\text{trip}} = 0.6 \text{ bar}$ (overpressure)

6 Commissioning

! NOTICE

The machine is shipped without oil.

Operation without oil will ruin the machine in short time!

- Prior to commissioning, the machine must be filled with oil, see Filling Oil [► 11].

⚠ CAUTION

During operation the surface of the machine may reach temperatures of more than 70°C.

Risk of burns!

- Avoid contact with the machine during and directly after operation.



⚠ CAUTION

Noise of running machine.

Risk of damage to hearing!

If persons are present in the vicinity of a non noise insulated machine over extended periods:

- Make sure that ear protection is being used.
- Make sure that the installation conditions (see Installation Conditions [► 8]) are complied with.
- Switch on the machine.
- Make sure that the maximum permissible number of starts does not exceed 12 starts per hour.

Version with water-oil heat exchanger:

- Open the water supply.
- After few minutes of operation, check the oil level and top up if necessary.

As soon as the machine is operated under normal operating conditions:

- Measure the motor current and record it as reference for future maintenance and troubleshooting work.

6.1 Conveying Condensable Vapours

Water vapour within the gas flow is tolerated within certain limits. The conveyance of other vapours shall be agreed upon with Busch.

If condensable vapours are to be conveyed:

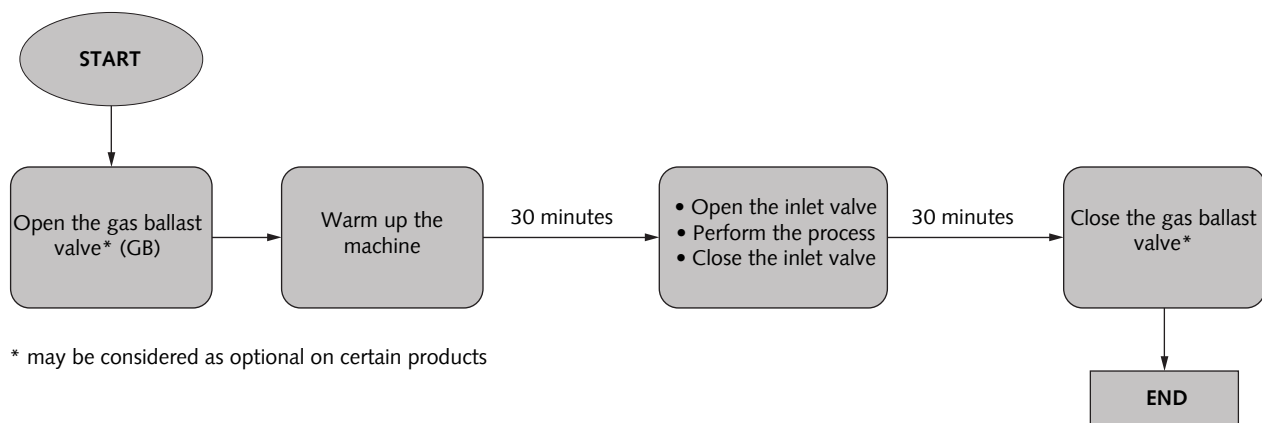

7 Maintenance



WARNING

Machines contaminated with hazardous material.

Risk of poisoning!

Risk of infection!

If the machine is contaminated with hazardous material:

- Wear appropriate personal protective equipment.

CAUTION

Hot surface.

Risk of burns!

- Prior to any action requiring touching the machine, let the machine cool down first.
- Shut down the machine and lock against inadvertent start up.
- Vent the connected lines to atmospheric pressure.

Version with water-oil heat exchanger:

- Turn off the water supply.

If necessary:

- Disconnect all connections.

7.1 Maintenance Schedule

The maintenance intervals depend very much on the individual operating conditions. The intervals given below are desired to be considered as starting values which should be shortened or extended as appropriate. Particularly heavy duty operation, such as high dust loads in the environment or in the process gas, other contamination or ingress of process material, can make it necessary to shorten the maintenance intervals significantly.

Interval	Maintenance work
Weekly	<ul style="list-style-type: none"> • Check the oil level, see Oil Level Inspection [► 16]. • Check the machine for oil leaks - in case of leaks have the machine repaired (contact Busch).
Monthly	In case of an inlet filter being installed: <ul style="list-style-type: none"> • Check the inlet filter cartridge, replace if necessary.
Every 2000 hours, at the latest after 6 months	<ul style="list-style-type: none"> • Change the oil, the oil filter (OF) and the exhaust filters (EF).
Every 6 months	<ul style="list-style-type: none"> • Clean the machine from dust and dirt. In case of a gas ballast valve (GB) being installed: <ul style="list-style-type: none"> • Clean the filter of the gas ballast valve.
Every 5 years	<ul style="list-style-type: none"> • Have a major overhaul on the machine (contact Busch).

7.2 Oil Level Inspection

- Shut down the machine.
- When the machine is stopped, wait 1 minute before checking the oil level.

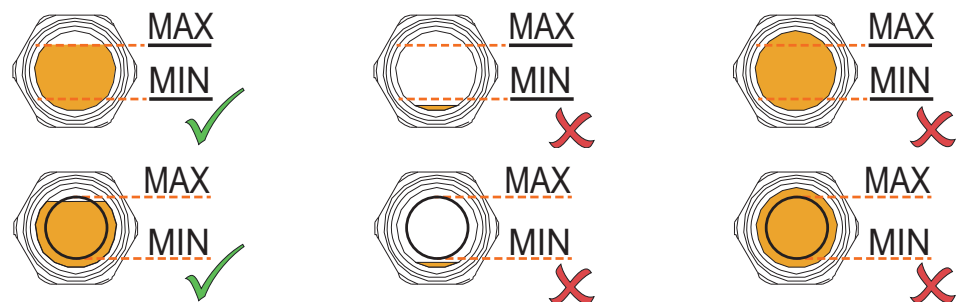

- Fill up if necessary, see Oil Filling [► 11].

7.3 Oil and Oil Filter Change

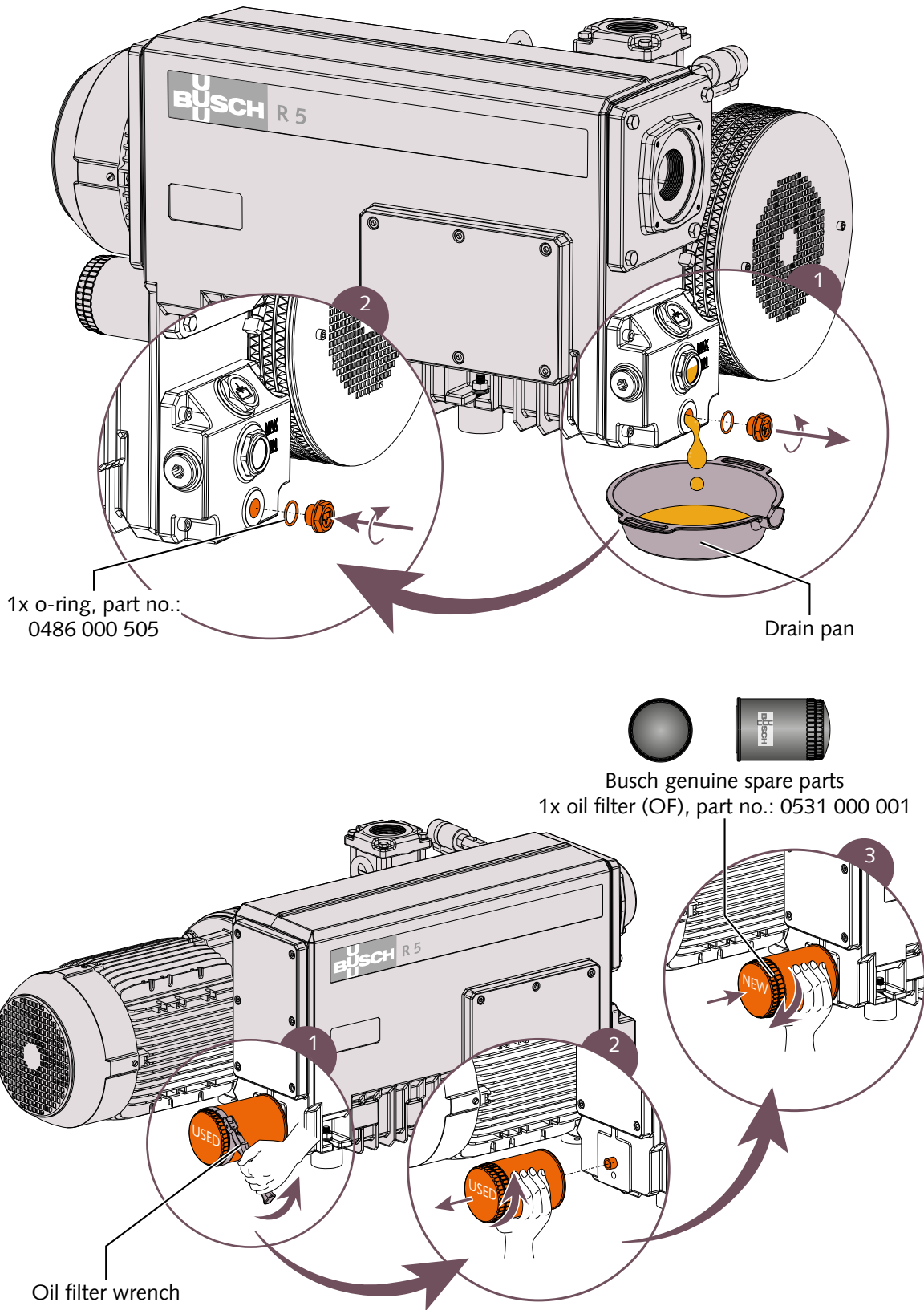

For oil type and oil capacity see Technical Data [▶ 23] and Oil [▶ 23].

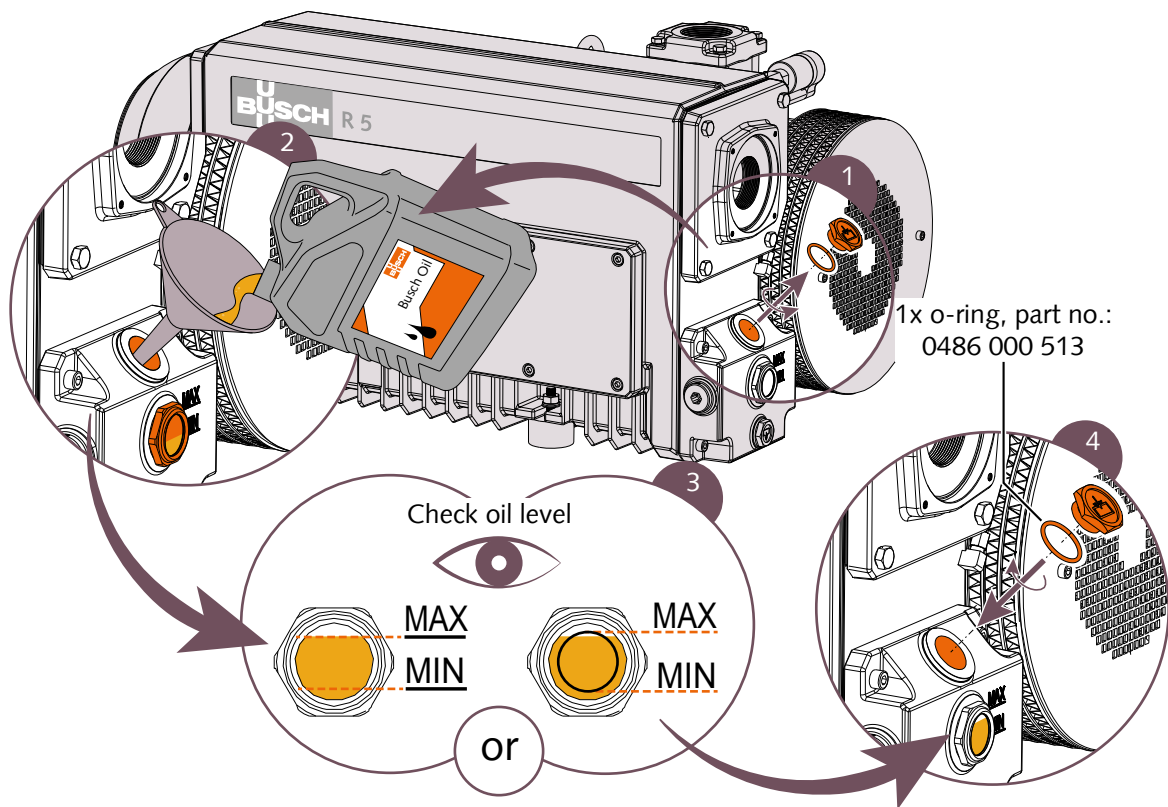

7.4 Exhaust Filter Change

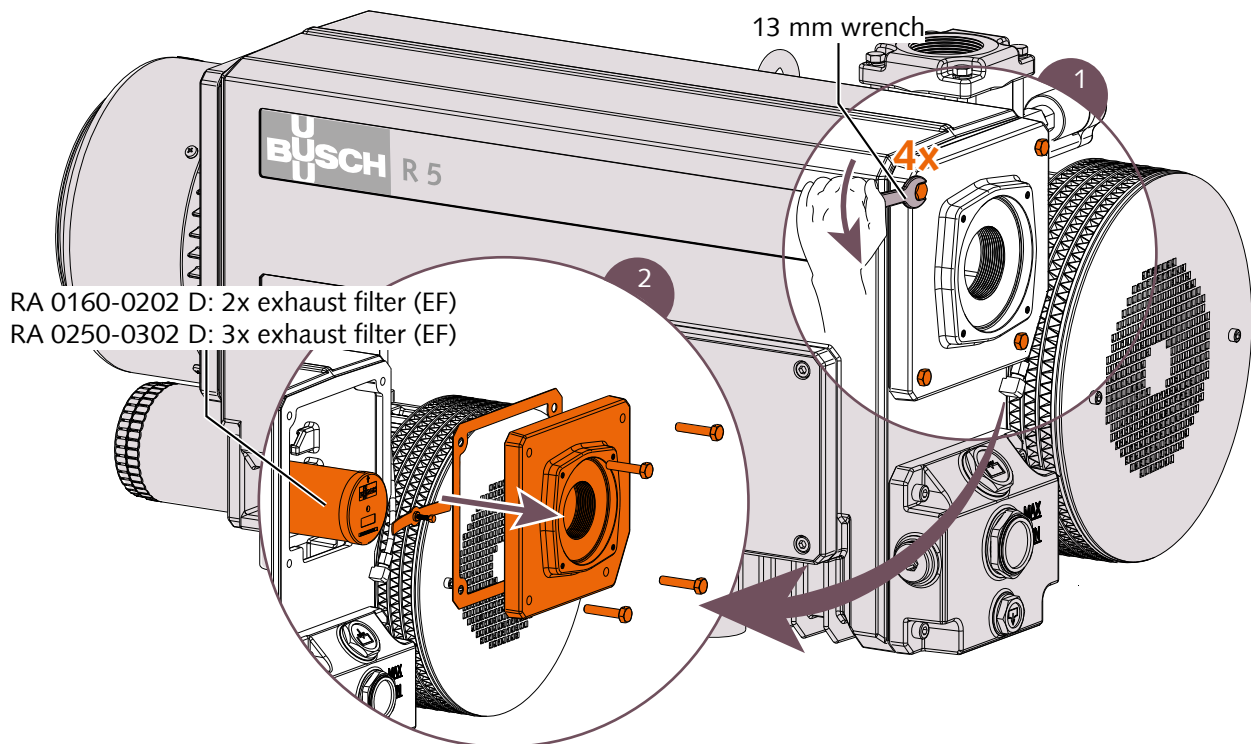

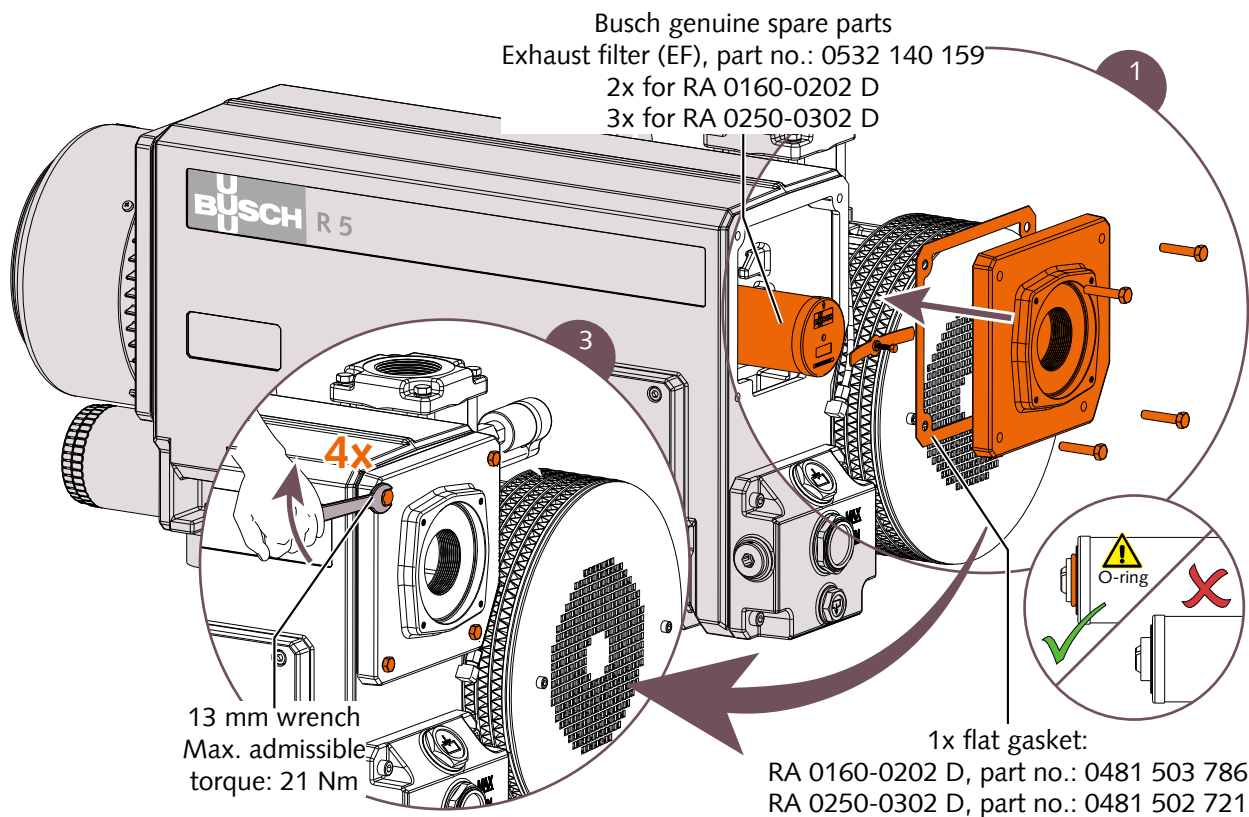

8 Overhaul

! NOTICE

Improper assembly.

Risk of premature failure!

Loss of efficiency!

- It is highly recommended that any dismantling of the machine that goes beyond anything that is described in this manual should be done through Busch.



⚠ WARNING

Machines contaminated with hazardous material.

Risk of poisoning!

Risk of infection!

If the machine is contaminated with hazardous material:

- Wear appropriate personal protective equipment.

In case of the machine having conveyed gas that was contaminated with foreign materials which are dangerous to health:

- Decontaminate the machine as well as possible and state the contamination status in a 'Declaration of Contamination'.

Busch will only accept machines that come with a completely filled in and legally binding signed 'Declaration of Contamination'.

(Form downloadable from www.buschvacuum.com)

9 Decommissioning

- Shut down the machine and lock against inadvertent start up.
- Vent the connected lines to atmospheric pressure.

Version with water-oil heat exchanger:

- Turn off the water supply.
- Disconnect the water supply.
- Open the water by-pass valve (WBV).
- Blow through the water cooling inlet with compressed air.
- Disconnect all connections.

If the machine is going to be stored:

- See Storage [▶ 7].

9.1 Dismantling and Disposal

- Drain the oil.
- Remove the exhaust filters.
- Remove the oil filter.
- Separate special waste from the machine.
- Dispose of special waste in compliance with applicable regulations.
- Dispose of the machine as scrap metal.

10 Spare Parts

NOTICE

Use of non-Busch genuine spare parts.

Risk of premature failure!

Loss of efficiency!

- The exclusive use of Busch genuine spare parts and consumables is recommended for the proper function of the machine and for granting of warranty.

Spare parts kit	Description	Part no.
Service kit (RA 0160 / 0202 D)	Includes all the necessary parts for main- tenance.	0992 516 594
Service kit (RA 0250 / 0302 D)	Includes all the necessary parts for main- tenance.	0992 516 595

If other parts are required:

- Contact your Busch representative for the detailed spare parts list.

11 Troubleshooting

⚡ DANGER

Live wires.

Risk of electrical shock.

- Electrical installation work must only be executed by qualified personnel.

⚠ CAUTION

Hot surface.

Risk of burns!

- Prior to any action requiring touching the machine, let the machine cool down first.

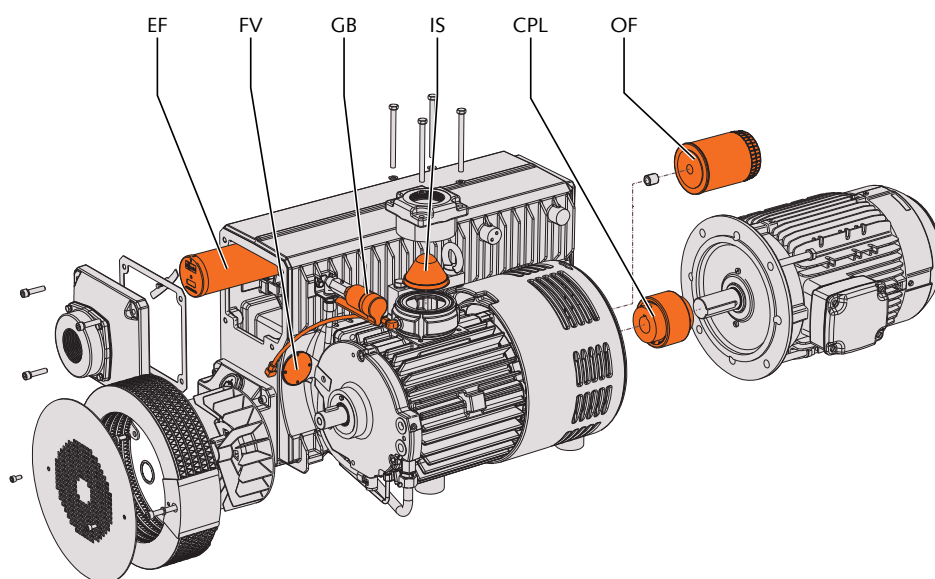

Problem	Possible Cause	Remedy
The machine does not start.	The motor is not supplied with the correct voltage.	• Check the power supply.
	The motor is defective.	• Replace the motor.
	The coupling (CPL) is defective.	• Replace the coupling (CPL).
The machine does not reach the usual pressure on the suction connection.	Oil level too low.	• Top up oil.
	The inlet screen (IS) is partially clogged.	• Clean the inlet screen (IS).
	The inlet filter cartridge (optional) is partially clogged.	• Replace the inlet filter cartridge.
	Internal parts are worn or damaged.	• Repair the machine (contact Busch).
The machine runs very noisily.	Worn coupling (CPL).	• Replace the coupling (CPL).
	Stuck vanes.	• Repair the machine (contact Busch).
	Defective bearings.	• Repair the machine (contact Busch).

The machine runs too hot.	Insufficient cooling.	<ul style="list-style-type: none"> Remove dust and dirt from the machine.
	Ambient temperature too high.	<ul style="list-style-type: none"> Observe the permitted ambient temperature.
	Oil level too low.	<ul style="list-style-type: none"> Top up oil.
	The exhaust filters (EF) are partially clogged.	<ul style="list-style-type: none"> Replace the exhaust filters (EF).
The machine fumes or expels oil droplets through the gas discharge.	The exhaust filters (EF) are partially clogged.	<ul style="list-style-type: none"> Replace the exhaust filters (EF).
	An exhaust filter (EF) with o-ring is not fitted properly.	<ul style="list-style-type: none"> Ensure the correct position of the exhaust filters (EF) and the o-rings.
	The float valve (FV) does not work properly.	<ul style="list-style-type: none"> Check the float valve and the oil pipe for clogging. Remove the clogging.
The oil is black.	Oil change intervals are too long.	<ul style="list-style-type: none"> Flush the machine (contact Busch).
	The inlet filter (optional) is defective.	<ul style="list-style-type: none"> Replace the inlet filter.
	The machine runs too hot.	<ul style="list-style-type: none"> See problem "The machine runs too hot".
The oil is emulsified.	The machine sucked in liquids or significant amounts of vapour.	<ul style="list-style-type: none"> Flush the machine (contact Busch). Clean the filter of the gas ballast valve (GB). Modify the operational mode (see Conveying Condensable Vapours [▶ 14]).

For the solution of problems not mentioned in the troubleshooting chart contact your Busch representative.

12 Technical Data

		RA 0160 D	RA 0202 D	RA 0250 D	RA 0302 D
Nominal pumping speed (50Hz / 60Hz)	m ³ /h	160 / 190	200 / 240	250 / 300	300 / 360
Ultimate pressure	hPa (mbar) abs.	See nameplate (NP)			
Nominal motor rating (50Hz / 60Hz)	kW	4 / 6.6	4 / 6.6	5.5 / 9.2	7.5 / 9.2
Nominal motor speed (50Hz / 60Hz)	min ⁻¹	1500 / 1800			
Noise level (EN ISO 2151) (50Hz / 60Hz)	dB(A)	70 / 72	72 / 74	72 / 74	74 / 76
Water vapour tolerance max. (with gas ballast valve)	hPa (mbar)	40			
Water vapour capacity (with gas ballast valve) (50Hz / 60Hz)	l / h	2.5 / 2.8	4 / 4.6	4.5 / 5	5 / 5.8
Operating temperature (50Hz / 60Hz)	°C	64 / 66	71 / 78	80 / 81	82 / 85
Max. allowable pressure in the oil mist separator	hPa (mbar) abs.	1600			
Max. allowable gas inlet tem- perature	°C	≤50 hPa (mbar) ► 150			
		>50 hPa (mbar) ► 80			
Ambient temperature range	°C	See Oil [► 23]			
Ambient pressure		Atmospheric pressure			
Oil capacity	l	5.0		6.5	
Weight approx.	kg	140		190	

13 Oil

	VM 100	VE 101	VSL 100
ISO-VG	100	100	100
Ambient temperature range [°C]	0 ... 30	0 ... 40	0 ... 40
Part number 1 L packaging	0831 000 060	0831 000 099	0831 122 573
Part number 5 L packaging	0831 000 059	0831 000 100	0831 122 572
Warning signal Oil temperature [°C]	90	110	110
Switch point / Trip signal Oil temperature [°C]	110	130	130

To know which oil has been filled in the machine, please refer to the nameplate (NP).

14 EU Declaration of Conformity

This Declaration of Conformity and the CE-mark affixed to the nameplate are valid for the machine within the Busch scope of delivery. This Declaration of Conformity is issued under the sole responsibility of the manufacturer. When this machine is integrated into superordinate machinery the manufacturer of the superordinate machinery (this may be the operating company) must conduct the conformity assessment process for the superordinate machine or plant, issue the Declaration of Conformity for it and affix the CE-mark.

The manufacturer

Ateliers Busch S.A.
Zone Industrielle
CH-2906 Chevenez



declare that the machine(s) **R 5 RA 0160 D; RA 0202 D; RA 0250 D; RA 0302 D**
 with a serial number from **C1701... to C1852...**

has (have) been manufactured in accordance with the European Directives:

- 'Machinery' 2006/42/EC
- 'Electromagnetic Compatibility' 2014/30/EU
- 'RoHS' 2011/65/EU, restriction of the use of certain hazardous substances in electrical and electronic equipment

and following the standards.

Standard	Title of the Standard
EN ISO 12100:2010	Safety of machinery - Basic concepts, general principles of design
EN ISO 13857:2008	Safety of machinery - Safety distances to prevent hazard zones being reached by the upper and lower limbs
EN 1012-1:2010 EN 1012-2:1996 + A1:2009	Compressors and vacuum pumps - Safety requirements - Part 1 and Part 2
EN ISO 2151:2008	Acoustics - Noise test code for compressors and vacuum pumps - Engineering method (grade 2)
EN 60204-1:2006	Safety of machinery - Electrical equipment of machines - Part 1: General requirements
EN 61000-6-2:2005	Electromagnetic compatibility (EMC) - Generic standards. Immunity for industrial environments
EN 61000-6-4:2007 + A1:2011	Electromagnetic compatibility (EMC) - Generic standards. Emission standard for industrial environments
EN ISO 13849-1:2015 ⁽¹⁾	Safety of machinery - Safety-related parts of control systems - Part 1: General principles for design

Person authorised to compile the technical file:

Gerd Rohweder
 Busch Dienste GmbH
 Schauinslandstr. 1
 DE-79689 Maulburg

Chevenez, 16.03.2016

Christian Hoffmann, General director

⁽¹⁾ In case control systems are integrated.

A large, empty rectangular box with a thin gray border, occupying most of the page. It is intended for writing a note.

Note

A large, empty rectangular box with a thin gray border, occupying most of the page below the 'Note' header. It is intended for the user to write their notes.

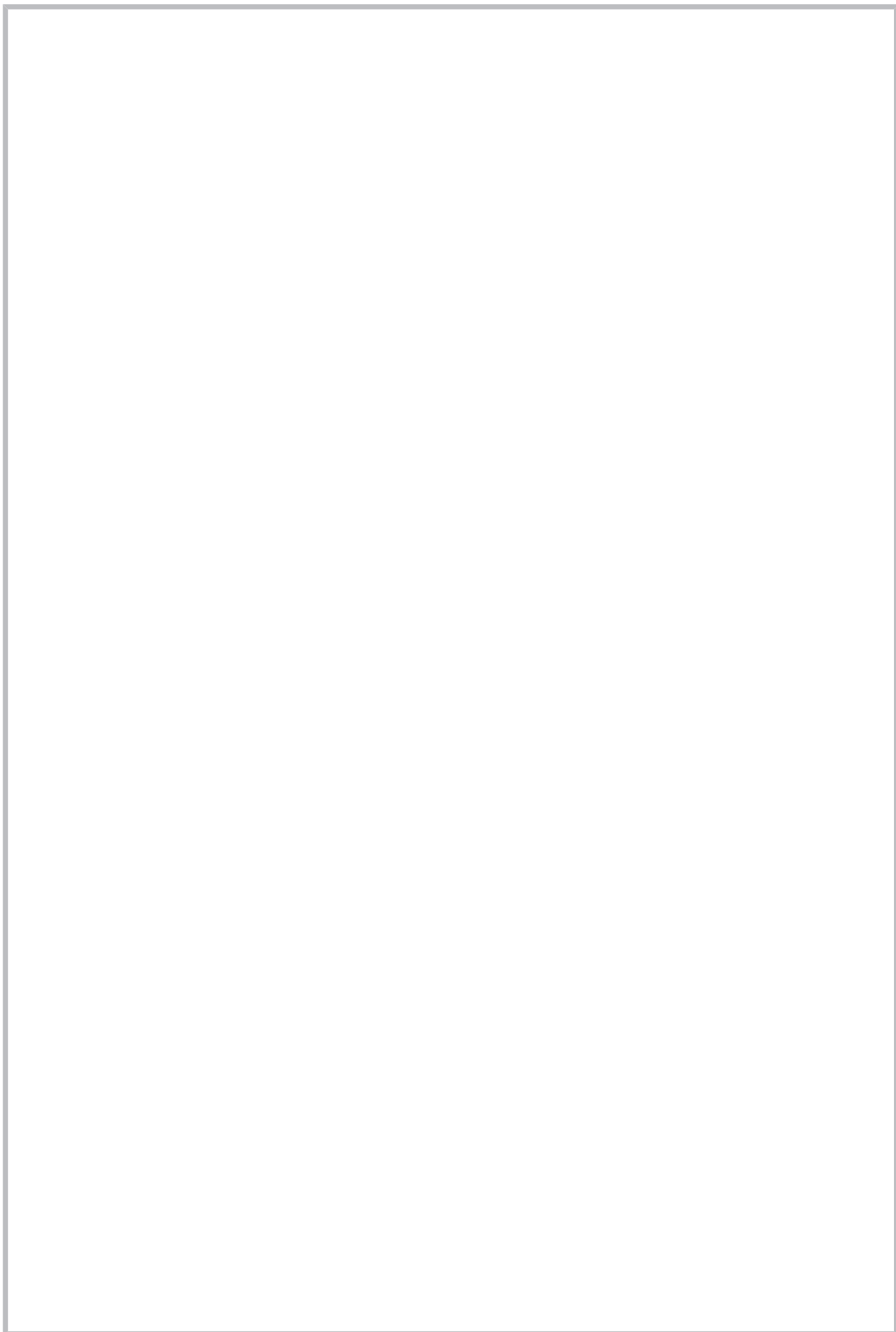
A large, empty rectangular box with a thin gray border, occupying most of the page. It is intended for writing a note.

Busch Vacuum Pumps and Systems

All over the World in Industry

Argentina

www.busch-vacuum.com.ar

Australia

www.busch.com.au

Austria

www.busch.at

Belgium

www.busch.be

Brazil

www.buschdobrasil.com.br

Canada

www.busch.ca

Chile

www.busch.cl

China

www.busch-china.com

Colombia

www.buschvacuum.co

Czech Republic

www.buschvacuum.cz

Denmark

www.busch.dk

Finland

www.busch.fi

France

www.busch.fr

Germany

www.busch.de

Hungary

www.buschvacuum.hu

India

www.buschindia.com

Ireland

www.busch.ie

Israel

www.busch.co.il

Italy

www.busch.it

Japan

www.busch.co.jp

Korea

www.busch.co.kr

Malaysia

www.busch.com.my

Mexico

www.busch.com.mx

Netherlands

www.busch.nl

New Zealand

www.busch.com.au

Norway

www.busch.no

Peru

www.busch.com.pe

Poland

www.busch.com.pl

Portugal

www.busch.pt

Russia

www.busch.ru

Singapore

www.busch.com.sg

South Africa

www.busch.co.za

Spain

www.buschiberica.es

Sweden

www.busch.se

Switzerland

www.busch.ch

Taiwan

www.busch.com.tw

Thailand

www.busch.co.th

Turkey

www.buschvacuum.com

United Arab Emirates

www.busch.ae

United Kingdom

www.busch.co.uk

USA

www.buschusa.com

